

Referência Completa

Tipo da Referência Conference Proceedings
Repositório sid.inpe.br/marciana/2003/09.12.09.34
Metadados sid.inpe.br/marciana/2003/09.12.09.34.40
Site mtc-m16.sid.inpe.br
Chave Secundária INPE-9783-PRE/5371
Chave de Citação TeixeiraOlivOliv:2003:TeFaDi
Autor 1 Teixeira, Adilson de Jesus
 2 Oliveira e Souza, Marcelo Lopes de
 3 Oliva, Álvaro Prieto
Grupo 1 DMC-INPE-MCT-BR
Afiliação 1 Instituto de Aeronáutica e Espaço (IAE)
 2 Instituto Nacional de Pesquisas Espaciais (INPE)
 3 Empresa Brasileira de Aeronáutica (EMBRAER)
Título Techniques for fault diagnosis in aerospace and automotive systems 
Nome do Evento International Congress and Exposition of the Mobility Technology, 12 (SAE).
Ano 2003
Editor(es) dos Engenheiros Automotivos, Sociedade
Título do Livro Anais
Data 8-20 nov. 2003
Cidade da Editora São Paulo
Editora (Publisher) SAEBrasil
Localização do Evento São Paulo,
Palavras-Chave fault diagnosis techniques, aerospace and automotive systems
Resumo This paper presents some techniques for fault diagnosis in aerospace and automotive systems. A diagnosis technique is an algorithm to detect and isolate fault components in a dynamic process, such as sensor biases, actuator malfunctions, leaks and equipment deterioration. Fault diagnosis is the first step to achieve fault tolerance, but the redundancy has to be included in the system. This redundancy can be either by hardware or software. In situations in which it is not possible to use hardware redundancy only the analytical redundancy approach can be used to design fault diagnosis systems. Methods based on analytical redundancy need no extra hardware, since they are based on mathematical models of the system.
Páginas 12
Organização Sociedade dos Engenheiros Automotivos, Sociedade
Idioma en
Tipo Secundário PRE CI
Area ETES
Última Atualização dos Metadados 2015:05.20.14.18.28 sid.inpe.br/bibdigital@80/2006/04.07.15.50 administrator
Estágio do Documento concluido
e-Mail (login) marciana
Grupo de Usuários administrator
Detentor da Cópia SID/SCD
Visibilidade shown
Transferível 1
Tipo do Conteúdo External Contribution
Data Secundária 20031120
Conteúdo da Pasta source não têm arquivos
Conteúdo da Pasta agreement não têm arquivos
Histórico 2015-05-20 14:18:28 :: administrator -> marciana :: 2003
Campos Vazios accessionnumber archivingpolicy archivist callnumber copyright creatorhistory descriptionlevel dissemination documentstage doi e-mailaddress edition electronicmailaddress format isbn issn label lineage mark mirrorrepository nextedition nexthigherunit notes numberoffiles numberofvolumes parameterlist parentrepositories previousedition progress project readergroup readergroup readpermission resumeid rightsholder secondarymark serieseditor session shorttitle size sponsor subject targetfile tertiarymark tertiarytype



MINISTÉRIO DA CIÊNCIA E TECNOLOGIA

INSTITUTO NACIONAL DE PESQUISAS ESPACIAIS

INPE-9783-PRE/5371

**TECHNIQUES FOR FAULT DIAGNOSIS IN AEROSPACE AND
AUTOMOTIVE SYSTEMS**

Adilson de Jesus Teixeira¹
Marcelo Lopes de Oliveira e Souza
Álvaro Prieto Oliva²

¹IAE – Instituto de Aeronáutica e Espaço

²EMBRAER – Empresa Brasileira de Aeronáutica

Paper accepted to be presented at the 12th International Congress and Exposition of the
Mobility Technology – SAEBrasil 2003, São Paulo-SP, Brasil, 18-20/11/2003.

INPE
São José dos Campos
2003

Publicado por:

**Coordenação de Ensino, Documentação e
Programas Especiais - CEP**

Instituto Nacional de Pesquisas Espaciais - INPE

Caixa Postal 515

12201-970 - São José dos Campos - SP - Brasil

Fone: (012) 345.6911

Fax: (012) 345.6919

E-Mail: marciana@sid.inpe.br

- Solicita-se intercâmbio
- We ask for exchange
- Si sollecita intercambio
- On demande l'échange
- Mann bittet un Austausch
- Pidese canje
- Просим обмена
- 歡迎著作交換
- 出版物交換不歸心

Publicação Externa - É permitida sua reprodução para interessados.



MINISTÉRIO DA CIÊNCIA E TECNOLOGIA
INSTITUTO NACIONAL DE PESQUISAS ESPACIAIS

INPE-9783-PRE/5371

**TECHNIQUES FOR FAULT DIAGNOSIS IN AEROSPACE AND
AUTOMOTIVE SYSTEMS**

Adilson de Jesus Teixeira¹
Marcelo Lopes de Oliveira e Souza
Álvaro Prieto Oliva²

¹IAE – Instituto de Aeronáutica e Espaço

²EMBRAER – Empresa Brasileira de Aeronáutica

Paper accepted to be presented at the 12th International Congress and Exposition of the
Mobility Technology – SAEBrasil 2003, 18-20/11/2003, São Paulo-SP, Brasil.

INPE
São José dos Campos
2003



MINISTÉRIO DA CIÊNCIA E TECNOLOGIA
INSTITUTO NACIONAL DE PESQUISAS ESPACIAIS

INPE-9783-PRE/5371

**TECHNIQUES FOR FAULT DIAGNOSIS IN AEROSPACE AND
AUTOMOTIVE SYSTEMS**

Adilson de Jesus Teixeira¹
Marcelo Lopes de Oliveira e Souza
Álvaro Prieto Oliva²

¹IAE – Instituto de Aeronáutica e Espaço

²EMBRAER – Empresa Brasileira de Aeronáutica

Paper accepted to be presented at the 12th International Congress and Exposition of the
Mobility Technology – SAEBrasil 2003, São Paulo-SP, Brasil, 18-20/11/2003.

INPE
São José dos Campos
2003

TECHNIQUES FOR FAULT DIAGNOSIS IN AEROSPACE AND AUTOMOTIVE SYSTEMS

Adilson de Jesus Teixeira
IAE - Instituto de Aeronáutica e Espaço

Marcelo Lopes de Oliveira e Souza
INPE - Instituto Nacional de Pesquisas Espaciais

Álvaro Prieto Oliva
EMBRAER – Empresa Brasileira de Aeronáutica

Copyright © 2002 Society of Automotive Engineers, Inc

ABSTRACT

This paper presents some techniques for fault diagnosis in aerospace and automotive systems. A diagnosis technique is an algorithm to detect and isolate fault components in a dynamic process, such as sensor biases, actuator malfunctions, leaks and equipment deterioration. Fault diagnosis is the first step to achieve fault tolerance, but the redundancy has to be included in the system. This redundancy can be either by hardware or software. In situations in which it is not possible to use hardware redundancy only the analytical redundancy approach can be used to design fault diagnosis systems. Methods based on analytical redundancy need no extra hardware, since they are based on mathematical models of the system.

INTRODUCTION

A diagnosis technique is an algorithm to detect and isolate (locate) faulty components in a dynamic process, such as sensor biases, actuator malfunctions, leaks and equipment deterioration. Fault diagnosis is the first step to achieve fault tolerance, but the redundancy has to be included in the system. This redundancy can be either by hardware (physical redundancy) or by software (analytical redundancy). Hardware redundancy, e.g., an extra sensor or extra actuator, can produce several problems associated with: cost, space, weight and complexity of the system. Besides, it has been observed that redundant components tend to have similar life expectancies; so the event that cause one component to fail probably will cause its redundant components to fail soon. There are even situations in which it is not possible to use hardware

redundancy; so, in these cases, only the analytical redundancy approach can be used to design a fault diagnosis systems. Methods based on analytical redundancy need no extra hardware because they are based on mathematical models of the system. The main components of such techniques are: 1) residual generations using models; 2) signature generation via statistical testing; and 3) signature analysis and diagnosis. Nowadays the analytical redundancy is feasible to implement because complex systems are designed with large process capacity.

In several cases, the fault in a sensor can be catastrophic if the control does not have any redundancy degree, physical or analytical. Due to this characteristics, it is very important to implement a control system with redundancy to these systems and to include the capacity to identify faults in the sensors as fast as possible, so that, it can reconfigure the use of the remaining sensors or even reconfigure the control law with fault for an alternative control law.

This paper bases mainly on techniques for fault diagnosis in aerospace and automotive system. To do so, the model of an aerospace vehicle is presented for inclusion of a fault detection scheme in instruments (IFD - Instrument Fault Detection) using the approach of the analytical redundancy. After is presented an example of an application of IFD in a system, for result evaluation.

BASIC CONCEPTS

FAULT – can be defined as a malfunction of any component of a system, causing since a loss of performance up to a total stop of its functions. According

to [1] the faults can be divided in:

- **Abrupt Fault:** fault that suddenly occurs and persists in a component.
- **Incipient Fault:** fault that develops slowly at a component.

The early detection of an incipient fault can help to avoid a total breakdown of the plant or even catastrophes that could result in loss of significant amount of material or serious personal injury. So, it is desired to have a **fault tolerant system**, that is, a system that can continue to do its task, even when there are hardware faults or software errors. But the implementation of such system is not easy to do.

We will use the words fault and failure as synonyms, although, strictly speaking, the term **failure** suggests complete breakdown, while **fault** may connote something tolerable.

According to the terminology used in [2], the fault detection and diagnostic consist of the following tasks:

- **Fault Detection:** detection that something is wrong in the system. Special emphasis is laid upon incipient faults rather than abrupt faults because incipient faults are harder to detect.
- **Fault Isolation:** determination of the fault origin.
- **Fault Identification:** determination of the gravity of the fault.

The classification of the faults contemplates, explicitly or implicitly, the context in which the problem of the detection/isolation is classified. A classification proposed by [2], corresponding to a model-based framework, considers three fault classes:

- **Addictive Measure Faults:** these are discrepancies between the measurements and true values of the plant output or between the measurements and true values of the plant input. Such faults describe sensor biases. They can also be used to describe actuator malfunctions. The discrepancy now is between the intended (computed) control value and the real value provided by the actuator.
- **Addictive Process Faults:** these are disturbances (unmeasured inputs) acting on the plant, usually ignored, but that cause a deviation in the plant outputs, independently of the measured inputs. Such faults describe the leaks, loads, etc. of the

plant.

- **Multiplicative Process Faults:** these are changes (abrupt or gradual) of the plant parameters. Such fault describes the deterioration of the plant components, such as partial or total loss of power, surface contamination, etc.

FAILURE DETECTION AND ISOLATION – The failure detection and isolation, according to [2], can be divided in the following methods:

1. **Limit Checking:** the signals measured from the plant are compared to predetermined limits, and if they exceed one of these limits, they will indicate a failure situation. In many systems there are two levels of limits: the first level serves only for warning, while the second level triggers emergency action.
2. **Installation of Special Sensors:** these may be basically the sensors that check limits in the hardware (e.g., temperature or pressure limits) or sensors measuring some special variables (e.g., sound, acoustics, vibration, elongation, etc).
3. **Installation of Multiple Sensors:** it is the physical redundancy (hardware redundancy). This approach is especially destined to detect and isolate sensor failures. Measurements of the same variable supplied by several sensors are compared. Any serious discrepancy is an indication of the failure of at least one sensor. The measurement that is probably considered correct may be selected through a voting system.
4. **Frequency Analysis of Plant Measurements:** some plant measurements have a typical frequency spectrum under normal operating conditions. Any deviation in this spectrum is an indication of abnormality. Certain types of failure may even have a characteristic signature in the spectrum that can be used for failure isolation.
5. **Expert Systems:** it is a different approach from those presented previously. It is aimed at evaluating the symptoms obtained by the detection hardware or software. The system usually consists of a combination of logical rules of the type: IF [symptom] AND [symptom] THEN [conclusion], where each conclusion can, in turn, to serve as an indication for the next logic rule until the final conclusion (the specific failure) is reached. The expert system may work on the information presented to it by the detection hardware/software or may interact with a human

operator, requesting information on a specific symptom and driving him or her through the entire logical process for the solution.

model of the process and they are divided in two groups: parameter estimation and parity space approaches, so they will not be covered by this paper.

A wide class of fault detection and isolation methods makes explicit use of the mathematical model of the plant, as the **model-based methods**, based on the idea of the analytical redundancy [3]. In contrast with the **physical redundancy**, where measurements of different sensors are compared, in the **analytical redundancy** the measurements supplied by a sensor are compared with the respective variable value obtained through the mathematical model. Such value is obtained through calculations that use current and/or previous measurements of another variable and the mathematical model that describes their relationships. The idea can still be extended only for the comparison of the values generated analytically, each of them being obtained through different calculations. In both cases, the resultant differences are called of **residues**.

While the residues have zero value in ideal situations, in practice, this rarely happens. Their deviations of this value are a combined result of the noise and of the faults. If the noise is negligible, the residues can be analyzed directly for detection of the fault. In the presence of significant noise, it is necessary to do a statistical analysis. In both cases logical patterns are generated, indicating which pattern can be considered normal and which can be considered of fault. Such patterns are called **fault signatures**. It should be observed that most of the fault detection and isolation methods don't use the incorporated information of the amplitude of the residues besides their relationships of the test thresholds.

RESIDUES – According to [4], the approach of residues can be divided in three subgroups:

- **Limit and Trend Checking:** this approach is the simplest imaginable. Sensor measures are tested against predefined limits and/or trends. This approach needs no mathematical model and is therefore simple to use. However, it is difficult to obtain a diagnosis of high performance;
- **Signal Analysis:** these approaches analyze signals, that is, the sensor outputs to obtain a diagnosis. The analysis can be made in the frequency domain or by using a signal model, e.g., an ARMA-model. If fault influences are greater than the input influences in well known frequencies bands, a time-frequency distribution method can be used, and
- **Process Model Based Residual Generation:** These methods are based on a mathematical

For approaching studies on residues, according to [4], more definitions are necessary:

A Residual (Parity Vector) $r(t)$ is a scalar or vector that has null or very small values, in the absence of faults, and has values different from zero when a fault occurs. The residual is, therefore, a vector in the parity space. This definition implies that a residual $r(t)$ has to be independent of, or at least insensitive to system states and unmeasured disturbances.

In case of linear systems, a general structure of a linear residual generator can be described as in the Figure 1. The transfer function from the fault $f(t)$ to the residual $r(t)$ is given by.

$$r(s) = H_r(s) G_f(s) f(s) = G_{rf}(s) \quad (1)$$

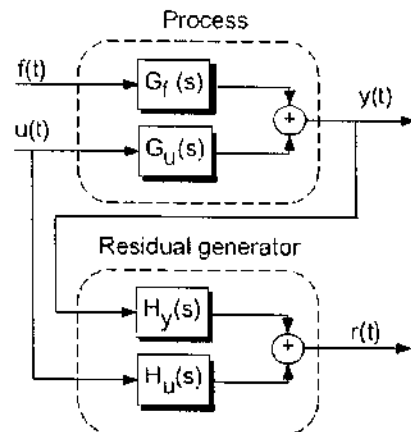

Figure 1. General structure of a linear residual generator.

The condition, for the system to be able to detect a fault in the residual, is based on the detectability definition. **Detectability** is the capability to detect the i^{th} fault that corresponds to the i^{th} column of the response matrix $[G_{rf}(s)]_i$, to be different from zero.

This condition, however, it is not enough in some practical situations. Assume that we have two residual generators as presented in the Figure 1. And in occurrence of a fault the residuals behave as in Figure 2. Here we see that we have a fundamentally different behavior between $r_1(t)$ and $r_2(t)$, because $r_1(t)$ only reflects transitions on the faulty signal while $r_2(t)$ has approximately the same shape of the faulty signal. Thus, $r_1(t)$ can not be used in a reliable IFD application even though it is clear that $G_{r_1f}(s) \neq 0$.

The difference between the two residuals in this example is the values of $G_{r,f}(0)$. Clearly we can see that the residual 1 have $G_{r_1,f}(0) = 0$ while the residual 2 have $G_{r_2,f}(0) \neq 0$. This leads to the definition of strong detectability. The i^{th} fault is said to have strong detectability if and only if:

$$[G_{r,f}(0)]_i \neq 0 \quad (2)$$

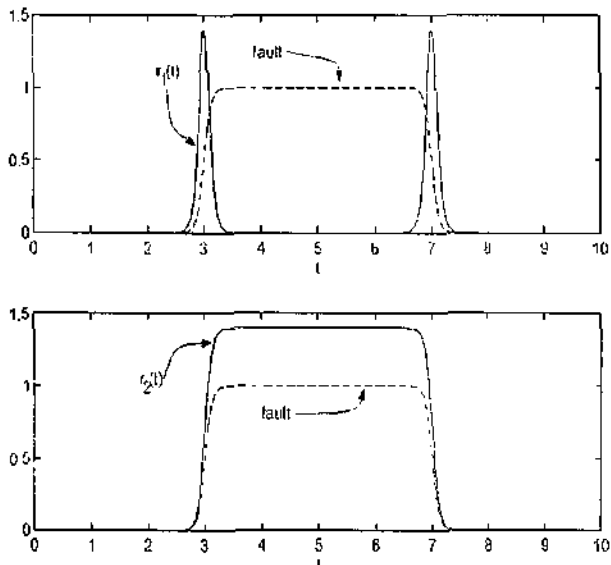

Figure 2 – Residuals Examples.

ISOLATION STRATEGIES – if we have residuals strongly detectable, two general methods are described in [5]:

- *Structured Residuals*
- *Fixed Direction Residuals.*

Structured Residuals – The conception of the structured residuals is based on a bank of residuals projected so that each residual is insensitive to a fault or subset of faults and it is sensitive to the remaining faults. For instance: if we want to isolate three faults, we can design three residuals $r_1(t)$, $r_2(t)$ and $r_3(t)$ so that each one is insensitive to only one fault. Then if residual $r_1(t)$ and $r_3(t)$ give the alarm, we can assume that fault 2 has occurred.

Structured Residuals can also be generated through a bank of observers. There are two general structures for a bank of observers, according to [1]: *Dedicated Observer Scheme (DOS)* and *Generalized Observer Scheme (GOS)*. In *DOS* structure, only the input signal of the system and one of the measurements are used as input signal for each observer. The i^{th} observer is, therefore, sensitive only to the fail of the i^{th} sensor. The *DOS* structure is presented in the Figure 3.

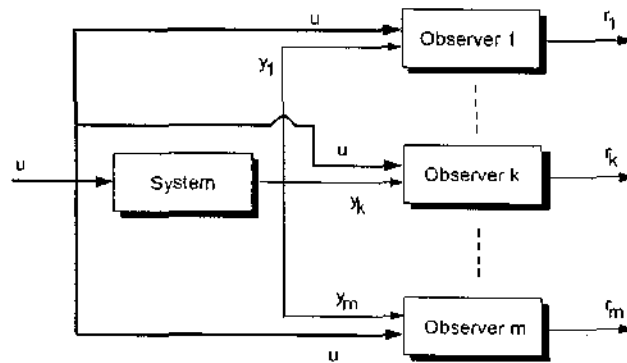

Figure 3 – DOS structure in IFD application.

In *GOS* structure, each observer is fed by the input signal of the system and for all but one measurement, making the i^{th} residual sensitive to all but the i^{th} measurement. The *GOS* structure is illustrated in Figure 4. Since always there are modeling errors and disturbances not modeled, the residuals are never null, even in the faulty free case. This can make some residuals to give the alarm that it shouldn't and vice versa. Therefore, it is more likely that a *GOS* bank of residuals is more reliable than a *DOS* bank in a realistic environment. This because if one residual in a *DOS* structure gives the false alarm, this immediately results in a bad fault decision. However, in a *GOS* structure, at least much than half of the residuals have to generate false alarms, if it uses the majority decision rule, to make a bad fault decision. If a residual pattern, i. e., a binary vector describing which residuals that have given the alarm, doesn't correspond to any fault patterns; a natural approach is to assume the fault pattern that has the smallest Hamming distance to the residual pattern. The Hamming distance is defined as the number of positions two binary vectors differ, for example: $H((1, 1, 0), (0, 1, 1)) = 2$.

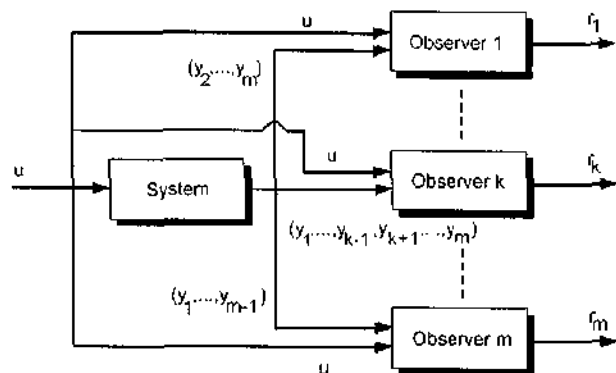

Figure 4 – GOS structure in IFD application.

As always there is a price to pay for the reliability increase, or robustness, a *GOS* structure can only detect one fault at a time while a *DOS* structure can detect faults

in all sensors at the same time. It is possible to extend the GOS structure with extra sensors and residuals to achieve possibilities to detect and to isolate multiple faults as in [6].

Fixed Directions Residuals – According to [4], this conception is the base of the fault detection filter where the residual vector get a specific direction depending on the fault that is acting upon the system. Figure 5 gives a geometrical representation of this type of residual when a sensor fault has occurred. The most probable fault can then be determined by finding the fault vector that has the smallest angle in relation to the residual.

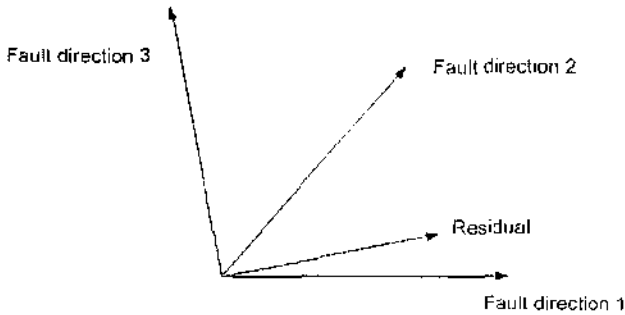

Figure 5 – Fixed direction residual.

It can be noted that a DOS structure can be considered as a fixed direction residual generator with the basis vectors as directions. A GOS structure can however not be considered as a fixed direction residual generator because a residual now is confined to a subspace of order $n-1$ (assuming that there are n residuals), instead of only one-dimensional subspace (the direction).

REQUIREMENTS OF ROBUSTNESS – According to [4], a problem to be considered is that unmeasured signals and error modeling are always present in the system. This makes it hard to keep the false alarm rate at an appropriate level. If it is known how the uncertainties influence the process, these uncertainties are denominated structured uncertainties. This information can be used to reduce or even eliminate their influence on the residuals. If it is not known how disturbances act upon the system, there is a little that can be done to decouple these influences. Actually we have not designed any robustness, the best that we can do is to maximize the sensibility to the faults and to minimize the sensibility to the disturbances over all operation points.

However it is possible to increase the robustness in the fault evaluation stage by using adaptive threshold levels or statistical decoupling in the step of decision threshold selection. This is called **passive robustness**. It is

not likely that one method can solve the entire robustness problem; a likely solution is one where disturbance decoupling is used side by side with adaptive thresholds.

MODEL BASED STRUCTURE – In this discussion, a model of a linear system, with time invariant parameters, represented in continuous time state space is given by:

$$\begin{aligned} \dot{x}(t) &= A \cdot x(t) + B \cdot u(t) \\ y(t) &= C \cdot x(t) + D \cdot u(t) \end{aligned} \quad (3)$$

We can have three types of general of faults:

1. **Sensor Fail:** modeled here as an additive and/or multiplicative fault of the plant output signal;
2. **Actuator Fail:** modeled as an additive fault of the input signal in the system dynamics, and
3. **Component Fail:** modeled as any distribution matrix that is added to the system dynamics matrix.

There are also uncertainties about the model and unmeasured inputs in the process. If these uncertainties are structured, that is, it is known how they enter the system dynamics; this information can be incorporated into the model.

In linear case and model with structured uncertainties, based on [4], the complete model can be represented by:

$$\begin{aligned} \dot{x}(t) &= A \cdot x(t) + B [u(t) + f_a(t)] + H f_c(t) + E d(t) \\ y(t) &= f_{sm} [C \cdot x(t) + D \cdot u(t)] + f_{sm}(t) \end{aligned} \quad (4)$$

where $f_a(t)$ denotes actuator faults, $f_c(t)$ is the component faults, $f_{sa}(t)$ is additive sensor fault, $f_{sm}(t)$ is multiplicative sensor fault, $d(t)$ is disturbances acting upon the system, H is the distribution matrix for components fault and E is the distribution matrix for disturbances acting upon the system.

A system with IFD, using analytical redundancy, allows to identify the fault sensor and to reconfigure the control law to use equivalent alternative information that should be supplied by this sensor.

ADDITIONAL CONSIDERATIONS – The final step of the procedure is the analysis of the residual logic patterns, with the objective of isolating the fault or the faults that generated the respective residue. Such analysis can be made through the comparison of a group of patterns or signatures known by belonging to a simple fail or for the use of some more complex logical procedure.

A general IFD scheme based on analytical redundancy, according to [4], can be illustrated as in Figure 6. It is represented by a block with measurements and control signals as input and a fault decision as output. Note that fault detection and isolation procedures using parameter identification techniques for the system, can be considered as a special class of the model based methods.

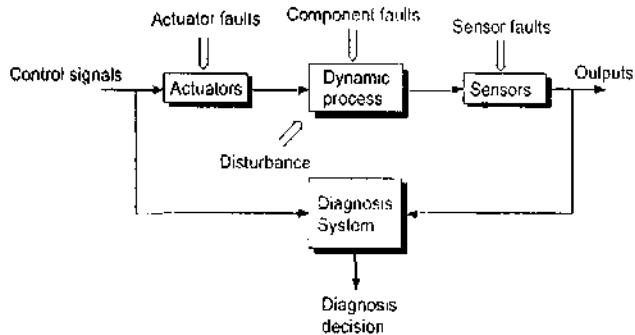

Figure 6 – Structure of a diagnosis system.

Once the fault is detected and isolated, the control law can be reconfigured, i. e., the fault signal can be changed for another redundant signal. In case where there are more than a redundant signal, it should be selected the one that presents better information quality for the desired signal.

Other relevant aspects in fault detection and isolation are the problems relative to the false alarm and alarm loss. **False Alarm** is the indication of the occurrence of a fault when the system is operating in its normal condition. **Alarm Loss**, on the other hand, is the indication that the system is operating normally, when it is in a faulty condition. The decision threshold between the fault state and normal state of operation should be chosen in such a way to minimize these two wrong and conflicting indications.

MODEL OF STUDY

BIBLIOGRAPHICAL REVISION – Following there are some revisions of good references for a SVL as indicated by [7]. *Methods for fault detection in dynamic systems can be found in [2], [4] and [8]. The mathematical model to describe the longitudinal motion of a satellite launcher vehicle can be obtained in [9]. The control system was designed through the LQR (Linear Quadratic Regulator) method as described in [10]. The method used for the observers' design can be found in [11]. The method used for robust observer's design can be found in [12]. And the decision functions adopted use the method of state estimator for fault detection in instruments described at chapter 2 of [1].*

Following there are another good references that can also be added. The detection and isolation of actuators and sensors faults, using the modified fault detection filter, can be found in [13]. The structure of the control system used in the Brazilian VLS, with focus in description of the algorithms used in its control system, can be found in [14], where there are indications of several references for this vehicle.

DESCRIPTION – The mathematical model used for this study is the longitudinal motion of a satellites launcher vehicle (SVL). As these types of vehicles are unstable, the fault in a sensor can be catastrophic if the control system doesn't have any redundancy degree, physical or analytical. The detailed description of the model used and the background to design the IFD is described in [7]. To facilitate the description of the equations, the terms that indicate functions of t will be omitted; and bold letters will identify the matrices and vectors.

The control system was designed with the purpose that the model follows the reference signal θ_{ref} (reference pitch attitude) and the regulation of the remaining state variables. Therefore, the control system will require three sensors to operate adequately, that is, sensors for w (normal velocity), q (pitch angular velocity) and θ (pitch attitude).

According to [7], the following model was used to design the longitudinal control system:

$$\begin{bmatrix} \dot{w} \\ \dot{q} \\ \dot{\theta} \\ \dot{e}_\theta \end{bmatrix} = \begin{bmatrix} Z_w & Z_q + U_0 & -g & 0 \\ M_w & M_q & 0 & 0 \\ 0 & 1 & 0 & 0 \\ 0 & 0 & -1 & 0 \end{bmatrix} * \begin{bmatrix} w \\ q \\ \theta \\ e_\theta \end{bmatrix} + \begin{bmatrix} Z_{\beta z} \\ M_{\beta z} \\ 0 \\ 0 \end{bmatrix} * \beta_z + \begin{bmatrix} 0 \\ 0 \\ 0 \\ 0 \end{bmatrix} * \theta_{ref}$$

$$y = Cx + Du \quad (5)$$

with $C = I$ e $D = 0$.

where w denotes the linear velocity along the z axis in the vehicle system, denominated normal velocity; q is the pitch-rate velocity, that is, the angular velocity around the y axis in the vehicle system; θ is the pitch attitude, that is, the angle of the attitude around the y axis in the vehicle system; e_θ is the pitch attitude error integral, included to keep the steady state error close to zero; β_z is the deflection angle of the actuator around the y axis in the vehicle system; $Z_w, Z_q, M_w, M_q, Z_{\beta z}$ e $M_{\beta z}$ are the aerodynamics derivatives of the satellites launcher vehicle, obtained in wind tunnel tests; U_0 is the module of the linear velocity of the vehicle, and g is the local gravity acceleration.

The control system was projected by the LQR method as described in [10]. The control law and the vector with

the feedback gains are given, respectively, in Eqs. (6) and (7). The parameter values used in the model and the gains used in the control law are presented in Table 1.

$$\beta_z = -G_1 x - G_0 \theta_{ref} \quad (6)$$

$$G_1 = [G_w \ G_q \ G_\theta \ G_{\theta\theta}] \quad (7)$$

Table 1 – Parameters used in the model and gains of the control law.

Parameter	Value
$Z_w [s^{-2}]$	-0,0968
$Z_q [s^{-2}]$	0,1631
$M_w [m^{-1}s^{-1}]$	0,0096
$M_q [s^{-1}]$	0,0568
$Z_{\beta z} [m s^{-2}]$	19,3761
$M_{\beta z} [s^{-2}]$	7,2769
$U_0 [m s^{-1}]$	544,46
$G [m s^{-2}]$	9,7886
$G_w [m^{-1}]$	0,0013
$G_q [s]$	1,4551
$G_\theta [rad]$	3,2581
$G_{\theta\theta} [rad]$	-3,1623
$G_0 [rad]$	-3,2570

Based on analytical redundancy, this project requests the use of state estimators in monitoring the subsystems to generate redundant signals, so it is necessary to include observers into the control law, to implement an alternative control law, that is, an **observer based control law**. The signals are then processed with the instrument signals to detect alarms and to identify which is the faulty sensor. This project had been designed through the DOS structure methodology.

The method used to design the observers can be found in [11]. The observer dynamics and the estimated state are given, respectively, by:

$$\dot{\hat{x}} = F \hat{x} + G y + H \beta_z \quad (8)$$

$$\hat{y}_s = N \hat{x} + M y + L \beta_z \quad (9)$$

where \hat{x} denotes the 2x1 observer state variables vector based on the sensor measure; y is the sensor measure; F is the 2x2 matrix that defines the observer dynamics, obtained from the design of a robust observer, according to [12]; G is the 2x1 vector that defines the sensor measure contribution, obtained to get $\{F, G\}$ controllable; H is the 2x1 vector that defines the control signal contribution that is applied to the plant, obtained through the relation $H = T B$, where the matrix T is obtained through the

Lyapunov equation $TA - FT = GC$; \hat{y}_s is the 2x1 estimated state vector based on sensor measure; M is the 2x1 vector that weighs the sensor measure contribution; N is the 2x2 matrix that weighs the observer state variable contribution and L is the 2x1 vector that weighs the input signal contribution. In this case, $L = 0$.

According to this method, the composed matrix $[M \ N]$ is obtained from: $[M \ N] = P^{-1}$, where $P^T = [C \ T]$. For the plant represented by Eq. (3), it is necessary to get one observer and one estimator for each state represented by each sensor. At Table 2 we have the parameters values for matrices and vectors for observers/estimators models.

Table 2 - Parameters values for matrices and vectors for observers/estimators models.

Matrix/Vector	Normal Velocity Parameters	
F_w	-20.0000	0.00000
	0.00000	-0.12240
G_w	1	
	1	
H_w	-9.08226	
	7.58401e2	
M_w	1.69922e-1	
	7.39270	
N_w	-3.35822	-3.49628e-2
	-1.46352e2	-1.94151
Matrix/Vector	Pitch Angle Velocity Parameters	
F_q	-20.0000	0.00000
	0.00000	-0.12240
G_q	1	
	1	
H_q	3.67157e-1	
	-1.37869e-5	
M_q	2.08708e3	
	-2.60643e1	
N_q	-4.13121e4	-3.84312e0
	5.16582e2	7.85226e0
Matrix/Vector	Pitch Attitude Parameters	
F_θ	-20.0000	0.00000
	0.00000	-0.12240
G_θ	1	
	1	
H_θ	-1.83578e-2	
	1.12638e-4	
M_θ	5.97643e2	
	2.00824e1	
N_θ	-1.05594e3	-7.64903e1
	-3.96390e2	-3.68747e-2

The decision functions will allow us to detect the faulty sensor, helping in deciding how to reconfigure the

control law. To design the decision functions we adopted the method shown at chapter 2 of [1] for a DOS structure methodology. For this structure, the residues are considered as been the module of the difference between the measurement supplied by each sensor and its respective estimated value. Each decision function, as presented in [7], is the product of two residues, as showed by Eqs. (10), (11) and (12):

$$\left. \begin{aligned} f_{\hat{q}/w} &= |q - \hat{y}_{q/w}| \\ f_{\hat{\theta}/w} &= |\theta - \hat{y}_{\theta/w}| \end{aligned} \right\} \eta_w = f_{\hat{q}/w} \cdot f_{\hat{\theta}/w} \quad (10)$$

$$\left. \begin{aligned} f_{\hat{w}/q} &= |w - \hat{y}_{w/q}| \\ f_{\hat{\theta}/q} &= |\theta - \hat{y}_{\theta/q}| \end{aligned} \right\} \eta_q = f_{\hat{w}/q} \cdot f_{\hat{\theta}/q} \quad (11)$$

$$\left. \begin{aligned} f_{\hat{w}/\theta} &= |w - \hat{y}_{w/\theta}| \\ f_{\hat{q}/\theta} &= |q - \hat{y}_{q/\theta}| \end{aligned} \right\} \eta_\theta = f_{\hat{w}/\theta} \cdot f_{\hat{q}/\theta} \quad (12)$$

Where η_w denotes the decision function for w sensor; η_q is the decision function for q sensor and η_θ is the decision function for θ sensor.

To get a better performance it was suggested in [7] to test also the derivative of the decision function. Here we used an approach slightly different: we test the difference between the derivative of the measurement and its respective estimated value. This consideration increases the performance in order to reduce the alarm loss rate of the decision function. By this way, adding the differences between the first and second derivative of each sensor measure and its respective estimated values, the decision functions become:

$$\begin{aligned} \eta_w &= |q - \hat{y}_{q/w}| |\theta - \hat{y}_{\theta/w}| + |\dot{q} - \hat{y}_{\dot{q}/w}| |\dot{\theta} - \hat{y}_{\dot{\theta}/w}| \\ &\quad + |\ddot{q} - \hat{y}_{\ddot{q}/w}| |\ddot{\theta} - \hat{y}_{\ddot{\theta}/w}| \end{aligned} \quad (13)$$

$$\begin{aligned} \eta_q &= |w - \hat{y}_{w/q}| |\theta - \hat{y}_{\theta/q}| + |\dot{w} - \hat{y}_{\dot{w}/q}| |\dot{\theta} - \hat{y}_{\dot{\theta}/q}| \\ &\quad + |\ddot{w} - \hat{y}_{\ddot{w}/q}| |\ddot{\theta} - \hat{y}_{\ddot{\theta}/q}| \end{aligned} \quad (14)$$

$$\begin{aligned} \eta_\theta &= |w - \hat{y}_{w/\theta}| |q - \hat{y}_{q/\theta}| + |\dot{w} - \hat{y}_{\dot{w}/\theta}| |\dot{q} - \hat{y}_{\dot{q}/\theta}| \\ &\quad + |\ddot{w} - \hat{y}_{\ddot{w}/\theta}| |\ddot{q} - \hat{y}_{\ddot{q}/\theta}| \end{aligned} \quad (15)$$

As the frequency bandwidth increases when we use the derivative and due to the fact that the system is subject to a sudden fault, we used a low pass filter to smooth the signal. In this case, considering the bandwidth for each sensor signal we included a 5 rad/s cutoff frequency low pass filter. So, we reduced the alarm loss rate in several faulty conditions and kept approximately the same performance to detect the fault.

After several tests, the following thresholds were adopted to detect the faults:

Fault of the sensor w: $\eta_w > 4650$

Fault of the sensor q: $\eta_q > 12$

Fault of the sensor θ : $\eta_\theta > 0.095$

Although this method is applied for one single fault, this IFD system can detect and isolate some cases of double faults. The selection of the redundant signal is shown in Table 3, and the block diagram using the IFD system is shown in Figure 7

Table 3 – Selection logic of the redundant signal.

Decision Function			Selection of the Redundant Signal						
η_w	η_q	η_θ	\hat{w}/q	\hat{w}/θ	\hat{q}/w	\hat{q}/θ	$\hat{\theta}/w$	$\hat{\theta}/q$	
0	0	0							
0	0	1						1	
0	1	0				1			
0	1	1			1		1		
1	0	0	1						
1	0	1	1					1	
1	1	0		1		1			
1	1	1	*	*	*	*	*	*	

Note:- number 1 at Decision Function column indicates a fault in the respective sensor;
- number 1 at Selection of the Redundant Signal indicates the redundant signal selected;
- cells with "*" are reserved when all sensors fail. In this case the system will need to use the redundant signal generated from an analytical model of the plant.

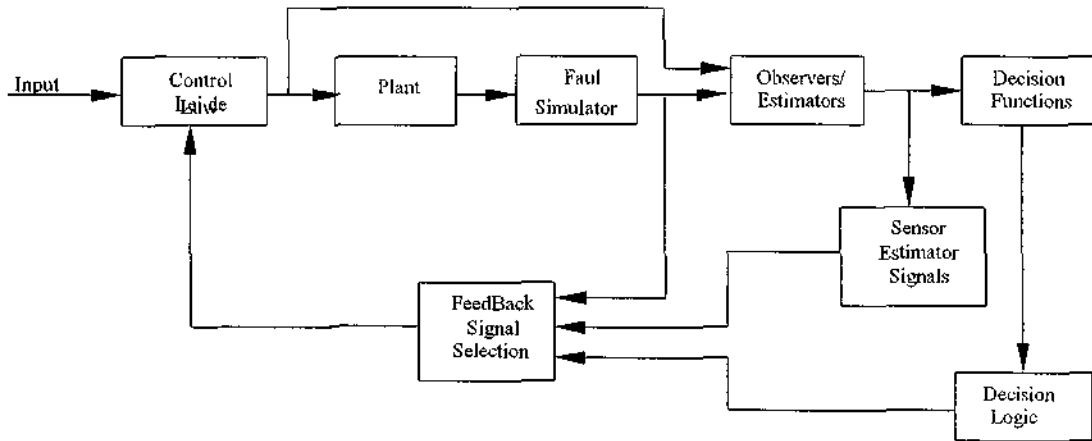

Figure 7 – System blocks model with IFD.

FAULT CASE STUDY – In this study we will only consider faults in sensors, therefore the faults $f_s(t)$ and $f_c(t)$ and the disturbance $d(t)$, presented in Eq. (3), will be considered null.

One sensor can have the following types of faults:

- **Zero:** when the sensor begins to supply only the zero value, that is, the sensor has an abrupt variation to the value zero;
- **Maximum Value:** when the sensor begins to supply only the maximum value in module, that is, the sensor has an abrupt variation to its maximum or minimum value;
- **Constant:** when the sensor begins to supply the last measurement made before the fault occurs;
- **Offset Drift:** when the value of the offset alters the measurement in function of time; and
- **Scale Factor Drift:** when the scale factor of the sensor alters the measurement in function of time.

As an example we will present one case for a fault of type zero.

Fault of Type Zero in Pitch Sensor – To analyze the performance the IFD system incorporated to the model we used the Simulink Simulation Environment, version 3, from MatLab, version 5.3.0. The system has to follow a random reference signal with uniform probability density between $-0,25\text{rad}$ and $0,25\text{rad}$ with sample time of $2,5\text{s}$. This sample time value was chosen to be smaller than the plant stabilization time for a step input. By this way, we can guarantee that the plant state variables will always be varying and we can evaluate the performance of the system

for fault detection, false alarm and alarm loss. We limited the simulation time in 50s , and use the integration method “ODE5 – Dormand-Prince” from MATLAB, with constant integration step of 10ms .

The fault was programmed to happen 4s after the beginning of the simulation and to remain in this condition during 30s . In Figure 8 there is the pitch attitude response of the plant with IFD system and with reconfiguration of the signals for the control law. Each graph is composed by two curves: the solid line represents the information resulting when there is a intermittent fault at pitch sensor and the dotted line represents the reference information when there is no fault in any sensor. It can be verified that the response of the system with IFD has approximately the same response of the system without fault.

In Figure 9 we can see the values of the decision functions. Only the decision function for pitch sensor (θ) changed quickly, as expected. It can also be seen that this decision function, during the fault, had values greater than the threshold indicating the respective sensor fault. The system presents the problem to indicate normal condition, when the system returns to the faulty free condition. So, during the time interval from 34s to 44s , the IFD system indicates a false alarm.

In Figure 10 we have the time interval for fault indication. The system detected the fault promptly and it hadn't fault loss indication during the fault presence.

COMMENTS AND CONCLUSIONS

The method presented here, with inclusion of the residues between the real and estimated measure derivatives, presented a great improvement in reduction of the alarm loss when compared with the method used by [7].

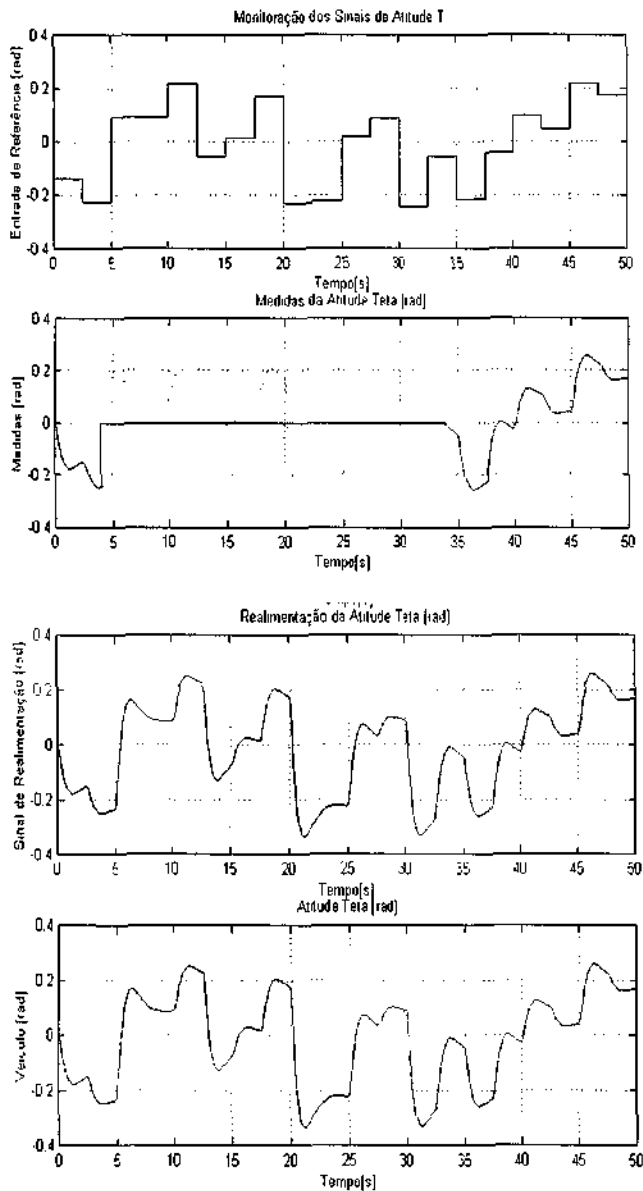

Figure 8 - System response with activation of type zero fault.

It should also be considered in the observers/estimators design that they should operate in a plant where the initial conditions are not null; otherwise, it will cause a false alarm indication for all sensors when the process is initiated.

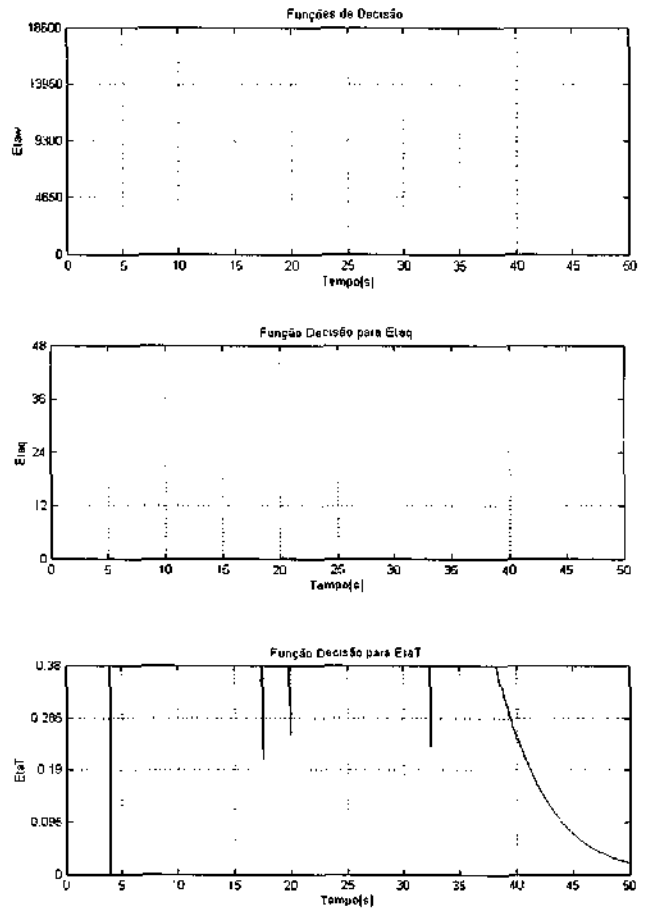

Figure 9 – Decision functions for type zero fault.

This method of determination of the fault based on the product of two residues presents the advantage of being able to detect the beginning of abrupt faults quickly, but with the disadvantage that it doesn't have strong fault detectability [4]; so it is difficult to get the appropriate decision threshold along the fault time. As two sensor residues are multiplied to compound the decision function, the influence of the faulty sensor also affects the decision function of the good sensors, so the IFD can indicate false alarm or alarm loss. Another disadvantage of this method is that the product of two residues generates a wider frequency spectrum.

For the methodology presented it was noticed that the IFD system has a good performance to detect and isolate abrupt faults type but its performance decrease in cases of intermittent fault. The decision logic was elaborated to work with multiple faults, but this condition requires the design of decision functions with strong detectability capability and that they allow to detect and isolate more than one fault simultaneously. In case that all sensors fail, it is necessary to design an analytical model of the plant.

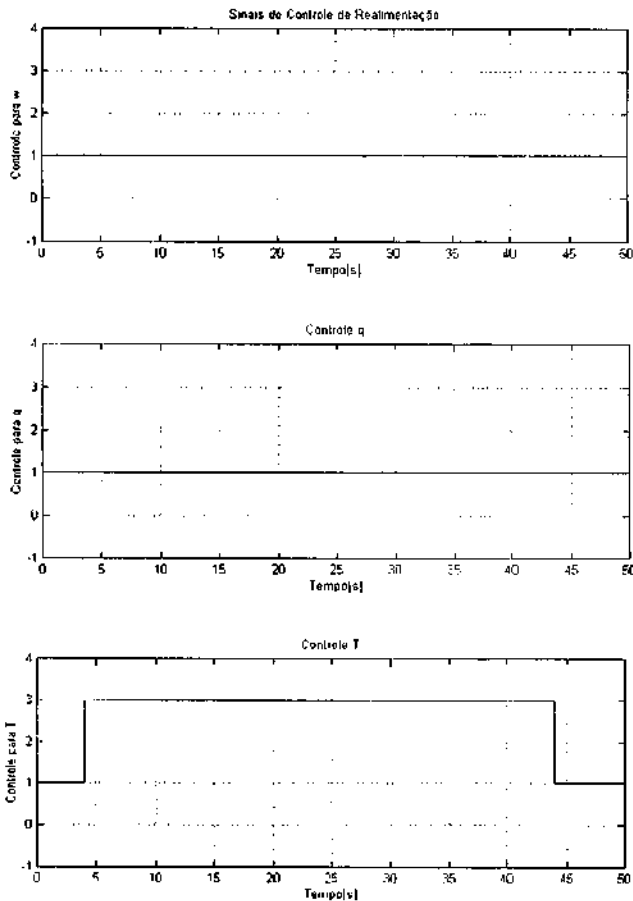

Figure 10 – Decision logic for type zero fault.

BIBLIOGRAPHICAL REFERENCES

[1] – Patton, R.; Frank, P. and Clark, R., “Fault Diagnosis in Dynamics Systems: Theory and Applications”. Prentice Hall Int. Series in Systems and Control Engineering, Englewood Cliffs, NJ, 1989.

[2] – Gertler, Janos J., “Survey of Model-Based Failure Detection and Isolation in Complex Plants”. IEEE Control Systems Magazine, Vol. 8, nº 6, pp. 3 – 11, December 1988.

[3] – Chow, E. Y. and Willsky, A. S., “Analytical Redundancy and the Design of Robust Failure Detection Systems”. IEEE Trans. Automatic Control, Vol. AC-29, nº 7, pp. 603-614, July 1984.

[4] – Frisk, Erik, “Model-based Fault Diagnosis Applied to a SI-Engine”. site www.vehicular.isy.liu.se, Linköping University, Linköping, Sweden, 1996.

[5] – Patton R. J., “Robust Model-Based Fault Diagnostic State of the Art”. In IFAC Fault Detection, Supervision and Safety for Technical Processes, pp. 1-24, Espoo, Finland, 1994.

[6] – Hsu, P. L., Lin K. L. and Shen, L. C., “Diagnosis of Multiple Sensor and Actuator Failures in Automotive Engines”. IEEE transactions on vehicular technology, 44(4):779-789, November 1995.

[7] – Oliva, Álvaro P., “Sensor Fault Detection and Analytical Redundancy Satellite Launcher Flight Control System”. SBA Controle & Automação, Vol. 9, nº. 3, pp. 156-164, 1998.

[8] – Willsky, The. S., “The Survey of Design Methods for Failure Detection in Dynamics Systems”. Automatica, Vol. 12, nº 6, pp. 601-611, November 1976.

[9] – McLean, D., “Automatic Flight Control Systems”. Englewood Cliffs, NJ, Prentice Hall Inc, 1990.

[10] – Rynaski, E. G., “Flight Control Synthesis Using Robust Output Observers”. Proc. AIAA Guidance and Control Conference, San Diego, CA, August, pp. 825-831, 1982.

[11] – Chen, C. T., “Introduction to Linear Systems Theory”. Holt, Rinehart and Winston Co., New York, 1984.

[12] – Doyle, J. C. and Stein, G., “Robustness with Observers”. IEEE Trans. on Automatic Control, Vol. AC-24, nº 4, pp. 607-611, August 1979.

[13] – Mello, A. F. e Souza M. L. O., “A Modified Detection Filter for Sensor Faults”. AAS/AIAA Space Flight Mechanics Meeting, Huntsville, AL, USA, 10-12. Paper AAS97-196, February 1997.

[14] – Leite Filho, W. C., “Estrutura do Sistema de Controle do VLS”. Controle & Instrumentação, Ano7, nº 72, pp. 71-77, Agosto 2002.

ABOUT THE AUTHOR - Adilson de Jesus Teixeira received the Electronics Engineer degree in 1981 from the University of Parahyba Valley, at S. José dos Campos, São Paulo, Brasil; and his Master of Science degree in Electronics Engineering in 1989 from the Aeronautics Technological Institute in the same city; he is a doctoral candidate in Space Engineering and Technology Course of the National Institute for Space Research-INPE, at the same city; and he is a Development Engineer at the Institute of Aeronautics and Space-IAE of the Aerospace Technological Center-CTA in the same city for more than ten years.

Email: adilson@iae.cta.br



Título

Techniques for Fault Diagnosis in Aerospace and Automotive Systems

Autor

Adilson de Jesus Teixeira, Marcelo Lopes de Oliveira e Souza, Alvaro Prieto Oliva

Tradutor

Não há

Editor

Sociedade dos Engenheiros Automotivos

Origem	Projeto	Série	No. de Páginas	No. de Fotos	No. de Mapas
DMC			12		

Tipo

RPQ PRE NTC PRP MAN PUD TAE

Divulgação

Externa Interna Reservada Lista de Distribuição Anexa

Periódico / Evento

12th International Congress and Exposition of the Mobility Technology - SAEBrasil 2003, São Paulo, SP, 18-20/11/2003.

Convênio

Autorização Preliminar

___/___/___ Titular da Unidade
Data

Revisão Técnica

Solicitada Dispensada
Recebida 17/06/2003 Devolvida 24/06/2003
Leonir Fernando Perondi
Coordenador Científico
Engenharia e Tecnologia Espacial
Titular de Nível "A"
Assinatura do Revisor

Revisão de Linguagem

Solicitada Dispensada
Recebida 17/06/2003 Devolvida 24/06/2003
Titular de Nível "A"
Assinatura do Revisor

Autorização Final

___/___/___ Titular da Unidade
Data

Palavras Chave

Fault Diagnosis Techniques, Aerospace and Automotive Systems

INPE - 9783 - PRE / 5374



Secretaria	
__/__/__ Data	Recebida __/__/__ Devolvida __/__/__
_____ Encaminhado Por	_____ Devolvido Por

Controle e Divulgação	
__/__/__ Data	Recebido Por: _____ Devolvido Para: _____
Pronto Para Publicação em: __/__/__	_____ Data
No. _____ Quant. _____	_____ Assinatura

Observações
Trabalho 164 do Brasil 2003 Congress .