

Reentrant Klystron Cavity as an Electromechanical Transducer

J. J. Barroso, P. J. Castro, L. A. Carneiro, and O. D. Aguiar
National Institute for Space Research/INPE
P. O. Box 515, S. José dos Campos 12245-670, SP, Brazil

Abstract. The resonance properties of reentrant cavities with circularly cylindrical and conical inserts are examined to quantify the resonant frequency dependence on the gap spacing between the end of the insert and the cavity's top plate. An experiment performed on a 1.0 GHz cavity fabricated from aluminum shows that the resonant frequency downshifts when the top plate made 1.0 mm thick is loaded at the center with weights as light as 10 g. This translates into a tuning coefficient of 3.0 MHz/mm, which can achieve a three fold increase through optimization of the cavity dimensions looking at application of the transducer in gravitational wave antennas.

Index Terms: reentrant cavity, electromechanical transducer

I. INTRODUCTION

Strong electric fields for accelerating or modulating an electron beam find important microwave applications in linear accelerators and RF power sources, where for a given cavity stored energy the strongest field is desired [1]. Also relying on intense fields to increase the energy sensitivity, electromagnetic cavity-based transducers [2] must be operated at high fields to maximize the electrical coupling to an external mechanical transformer. A cavity of this sort is usually accomplished by a reentrant klystron cavity (Fig. 1) where intense electric fields develop across a short gap.

In this paper we examine both theoretically and experimentally the resonance properties of azimuthally symmetric reentrant cavities, namely the relationship between the resonant frequency and the cavity dimensions with emphasis on how the frequency varies when the top plate is subjected to mechanical deformation due to an externally applied force.

II. CAVITY ANALYSIS

As pictured in Fig. 1, for a small gap spacing the electric field lines of the corresponding operation mode run in the gap region as from one plate to the other of a parallel plate capacitor, whereas in the rest of the cavity the field is substantially as in a terminated coaxial line.

Joaquim J. Barroso, barroso@plasma.inpe.br, Pedro J. de Castro, castro@plasma.inpe.br, Leandro A. Carneiro, leandro04@h8.ita.br, Odylio D. Aguiar, odylio@das.inpe.br.
This work was supported by FAPESP, SP, Brazil.

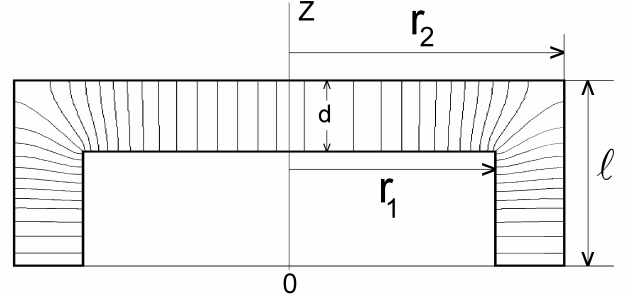

Fig. 1. Reentrant cavity schematic showing electric field lines

On condition that the gap spacing d is much shorter than the resonant wavelength the concept of lumped circuit elements becomes meaningful, whereby we treat the reentrant cavity as a shorted coaxial line terminated by a capacitor (Fig. 2).

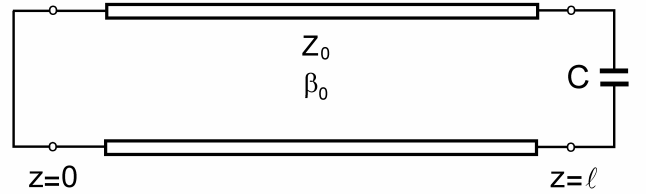

Fig. 2. Approximate equivalent circuit of the cavity in Fig. 1

Thus for a line of length ℓ , outer diameter $2r_2$, inner diameter $2r_1$, and terminal capacitance C the resonance condition requires that the loop impedance be zero, so that

$$jZ_0 \tan \mathbf{b}_0 \ell + \frac{1}{j\omega_0 C} = 0 \quad (1)$$

where $\mathbf{b}_0 = 2\mathbf{p} / \mathbf{l}_0 = \omega_0 \sqrt{\mathbf{m}_0 \mathbf{e}_0}$, $Z_0 = (1/2) \sqrt{\mathbf{m}_0 \mathbf{e}_0} \ln(r_2/r_1)$ and in a first approximation the gap capacitance is expressed as $C = \mathbf{e}_0 (\mathbf{p} r_1^2 / d)$. Assuming $\mathbf{b}_0 \ell \ll 1$, (1) simplifies to $\omega_0 C Z_0 \mathbf{b}_0 \ell = 1$ giving the resonant wavelength

$$\mathbf{l}_0 = r_1 \sqrt{2\mathbf{p}^2 \frac{\ell}{d} \ln \frac{r_2}{r_1}} \quad (2)$$

We note that if d is small compared to ℓ , as we are assuming, then \mathbf{I}_0 is large compared to r_1 . If, as is usually the case r_1 is of the same order of magnitude as r_2 and ℓ , then this means that \mathbf{I}_0 is large compared to all the dimensions of the cavity, justifying our assumption that the cavity can be treated as a lumped constant problem. Then if we wish to design a cavity for a given \mathbf{I}_0 , we see that the smaller d is, the smaller the cavity dimensions become, so that we can make in this way a conveniently small cavity resonant at a long wavelength. Although enlightening, the simple formula (2) does not provide an accurate estimate of the resonant frequency (in some cases the error may be larger than 40%) as its derivation lacks the cavity capacitance that accounts for the fringing fields in the transition region intermediate the coaxial and gap spaces. Calculated as [3],

$$C_1 = 4\mathbf{e}_0 r_1 \ln \frac{e\sqrt{(r_2^2 - r_1^2) + \ell^2}}{2d} \quad (3)$$

the cavity capacitance C_1 when added to C_0 much improves the accuracy of the equivalent circuit. Generalizing the configuration shown in Fig. 1, a reentrant cavity with a coaxial conical insert (Fig. 3) has been modeled by Fujisawa [3] as a lumped LC circuit leading to the following parameters:

$$\frac{L}{\mathbf{m}_0} = \frac{\ell}{2\mathbf{p}} \left(\ln \frac{er_2}{r_1} - \frac{r_0}{r_1 - r_0} \ln \frac{r_1}{r_0} \right) \quad (4)$$

$$\frac{C_0}{\mathbf{e}_0} = \frac{\mathbf{p}\bar{r}_0^2}{d} \quad (5)$$

$$\frac{C_1}{\mathbf{e}_0} = \frac{\mathbf{p}(r_0^2 - \bar{r}_0^2)}{d} + \frac{2\mathbf{p}}{\mathbf{a}} \left(r_0 \ln \frac{e\ell_M \sin \mathbf{a}}{d} + \frac{d \cot \mathbf{a}}{2} \ln \frac{\sqrt{e}\ell_M \sin \mathbf{a}}{d} \right) \quad (6)$$

where $\ell_M =$

$$\frac{\sqrt{[2(r_1 - r_0)^2 + 3(r_2 - r_1)(r_1 + r_2 - 2r_0)]^2 + \ell^2 (3r_2 - 2r_1 - r_0)^2}}{3(2r_2 - r_1 - r_0)} \quad (7)$$

$$\mathbf{a} = \tan^{-1} \frac{\ell - d}{r_1 - \bar{r}_0} \quad (8)$$

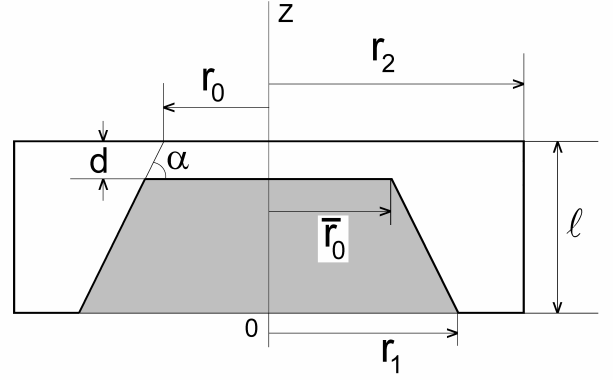

Fig.3. Definition of geometrical parameters for the reentrant cavity with coaxial conical insert

for which the error incurred in estimating the resonant frequency $f_0 = 1/2\mathbf{p}\sqrt{L(C_0 + C_1)}$ lies within a few percent as has been verified by Fujisawa [3] upon comparison with experiments. Accordingly, the accuracy of the formulas becomes better for larger r_0/ℓ_M and smaller ℓ_M/λ_0 , indicating the post radius and the resonant wavelength compared with the relative size of the cavity.

To foresee the predictions of (4-8) we examine below how the electro-dynamical properties of the reentrant cavity relate to the shape of the coaxial insert by considering two types of posts: a truncated cone and a circular cylinder, the latter of which the general expressions (6-8) apply when $\alpha = \pi/2$ ($r_1 = r_0$, Fig. 3). Markedly different for each coaxial insert, the plots in Fig. 4 show the dependence of resonant frequency f_0 on radius r_1 for fixed major radius $r_2 (=3.5$ cm) and cavity length $\ell (=1.4$ cm) with gap spacing d varying from 0.2 mm to 1.0 mm in steps of 0.2 mm. For the circularly cylindrical insert (Fig. 4(a)), f_0 starts decreasing for increasing r_1 and after reaching a flat region all the curves come nearer to the each other at large values of r_1 , eventually merging to a single curve in which the particular behavior entailed separately by the gap d on each curve is lost. With most the electromagnetic energy stored in the gap region and with the electric-field lines running axially, this regime ($r_1 \rightarrow r_2$) closely resembles the TM_{010} -mode operation in a circular cavity. In fact we note that the frequency curves going upward tend to an asymptotic value that is consistent with the resonant frequency of a TM_{010} -mode cavity with radius $r_2 = 3.5$ cm, i.e. $f_{\text{TM}_{010}} = (15/\pi)(\chi_{01}/r_2) = 3.28$ GHz, (where $\chi_{01} = 2.4048$ is the first zero of the Bessel function $J_0(\chi)$). By contrast, for the cavity with the conical insert (Fig. 4(b)) all the frequency curves slope upward and keep from approaching to the each other as r_1 increases. Moreover, we remark that the frequency separation given by the upper and innermost curves, for instance, at $r_1 = 2.0$ cm, for the uniform cavity (0.57GHz) is nearly half that for the cavity with tapered insert (0.97 GHz), which thus exhibits higher sensitivity to variations in d . To verify the resonance properties of the reentrant cavity with tapered insert an experiment is carried out in the next section.

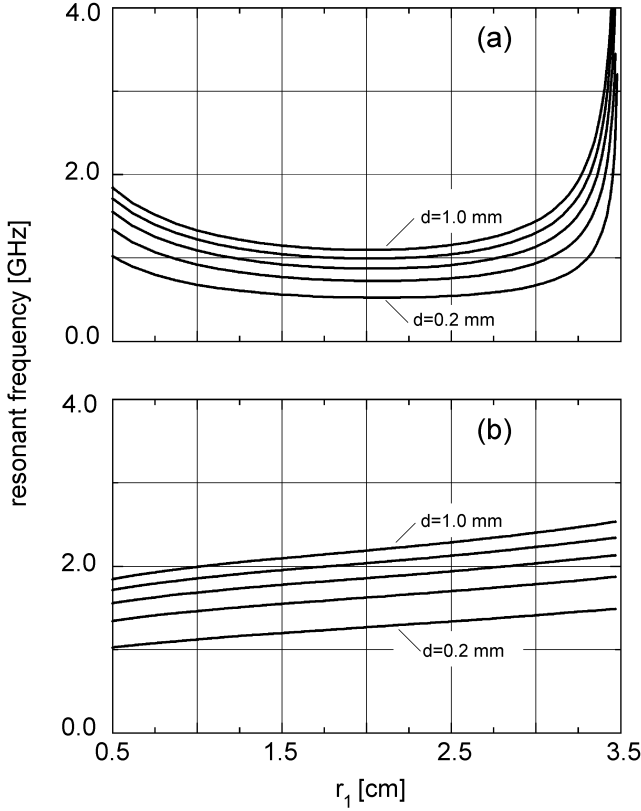

Fig. 4. Resonant frequencies as function of the inner radius r_1 for reentrant cavities with (a) circularly cylindrical and (b) conical inserts. The curves are parameterized at increments of 0.2 mm in the gap d .

III. EXPERIMENT

The resonance properties of a reentrant cavity with conical insert is experimentally examined by looking at the effect on the resonant frequency of reducing the gap spacing through application of a bending force at the center of the circular top plate with clamped edges. Fabricated from aluminum, the cavity has dimensions to allow operation in the klystron mode (with radial and axial electric field lines) around 1.0 GHz, a value well below the cutoff frequencies of potentially competing modes, since the major radius r_2 ($=3.2$ cm) being constrained to $r_2 < \lambda_0 \chi_{11} / (2\pi)$ where $\chi_{11} = 1.8411$, the first root of $J_1(\chi) = 0$, bounds the lower frequencies for propagation of either TM or TE modes on $f_c = (c/2\pi)(\chi_{11}/r_2) = 2.5$ GHz.

The coaxial insert is a truncated cone of radii $\bar{r}_0 = 0.5$ cm, $r_1 = 1.00$ cm and height that provides a gap of 0.2 mm between the end of the post and the upper plate made 1.0 mm thick. Resonant frequencies are measured by using the reflection-type circuit configuration in Fig. 5 where the cavity fields are both excited and detected by means of a single electric probe inserted through a 1.0-mm-diameter hole drilled halfway across the cylindrical wall, as illustrated in Fig. 6.

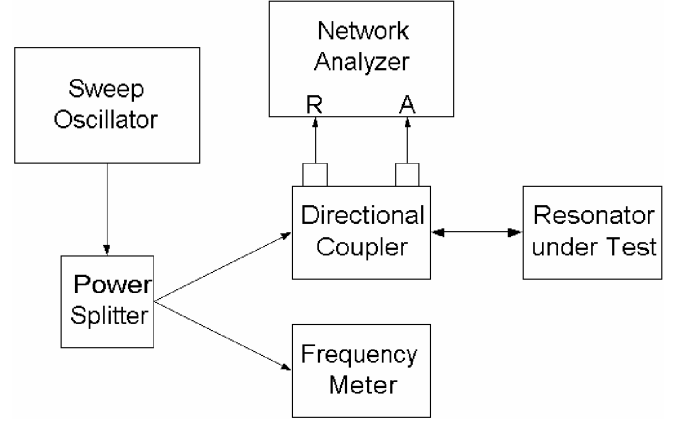

Fig. 5. Experimental setup to measure resonant frequencies

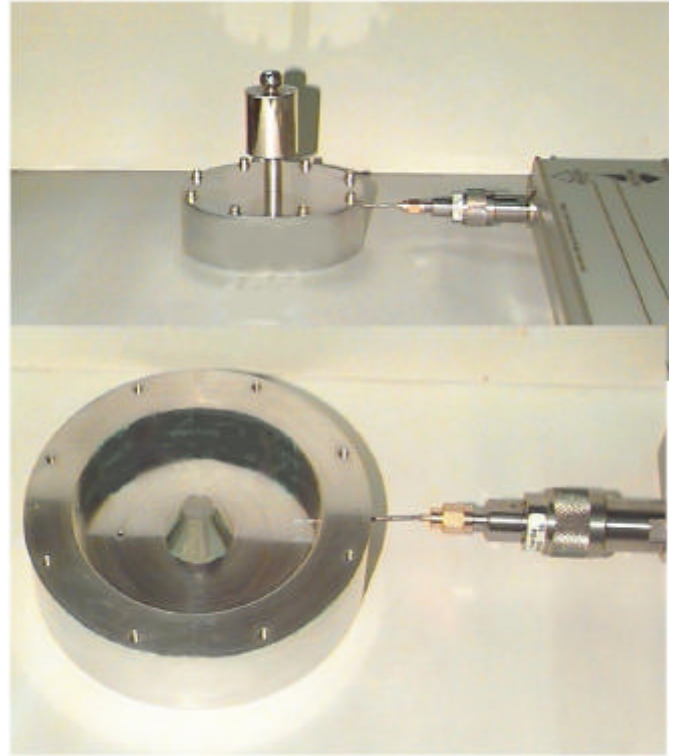

Fig. 6. Reentrant cavity under test

On applying a deflection force (using a set of calibrated weights) we then measure the corresponding downshifted frequencies, which are compared in Fig. 7 with calculated values. In the calculation, the nominal gap spacing d ($=0.2$ mm) in (3)-(7) is reduced by the maximum deflection δ_{\max} at the center (Fig. 8) determined from the following expression that gives the deflections due to pure bending of a clamped circular plate loaded at the center [4]:

$$d(r, P) = \frac{Pr^2}{8pD} \ln \frac{r}{r_2} + \frac{P}{16pD} (r_2^2 - r^2) \quad (9)$$

where P is the load applied, $D = Eh^3/12(1-\nu^2)$ denotes the flexural rigidity of the plate of thickness $h=1.0$ mm, modulus of elasticity $E=69.0$ GPa and Poisson's ratio $\nu=0.3$. We see in Fig. 7 that a weight of mass as low as 10 g loaded on the plate is unambiguously ascertained, with the deflected plate downshifting the free-loading 1.2003 GHz resonant frequency to 1.1979 GHz, which lies within 5.6% above the calculated value of 1.1309 GHz. Accordingly, since the cavity parameters $r_0/\ell_M=0.567$ and $\ell_M/\lambda_0=0.065$ are within the applicability region ($r_0/\ell_M > 1/3$) of the formulas, the calculated values stay below those calculated within an error of about 5.0 % in the observed range of frequencies. We note in addition that the frequency calculation assumes a flat spaced $d-\delta_{\max}$ apart from the top of the conical post, while in the actual experiment the deflected plate takes on the shape of a concave surface as illustrated in Fig. 8. And of course, had we considered the gap d reduced by half the maximum displacement, $d-\delta_{\max}/2$, the resulting calculated curve would have appeared closer to the experimental points, for the klystron-mode resonant frequency increases with the gap spacing.

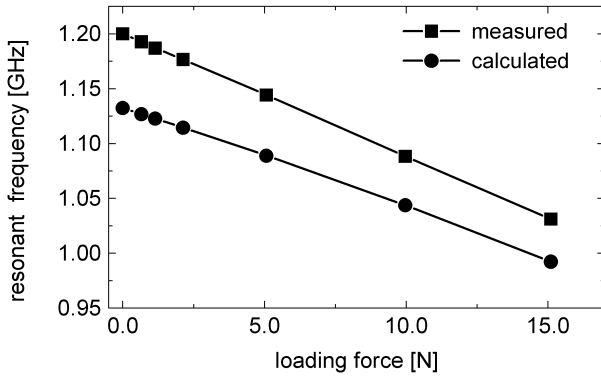

Fig. 7. Measured and calculated resonant frequencies as function of the loading force.

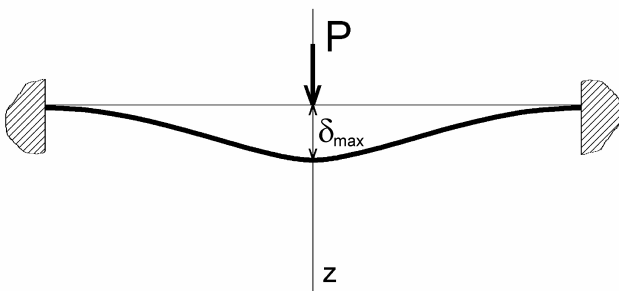

Fig. 8. Deflection of a clamped plate loaded at the center

IV. CONCLUSION

We have discussed the feasibility of a 1.0 GHz reentrant cavity as a parametric transducer by demonstrating in an exploratory experiment the transducer sensitivity to deflections of the 7.0-cm-diameter, 1.0-mm thick aluminum plate when loaded with weights as light as 10g. While showing high energy sensitivity, the transducer tuning coefficient $\Delta f/\Delta d=3.0$ MHz/ μm , which converts displacement to electrical units. Through proper selection of the cavity geometry by increasing r_1 (with r_2 and ℓ fixed) and reducing both \bar{r}_0 and the gap d , the tuning coefficient can achieve a three fold increase aiming at the device application in a resonant mass gravitational wave antenna under development at INPE [5,6]. In this experiment the reentrant cavity actually operates at 10.0 GHz, with its dimensions (in comparison with the 1.0 GHz prototype described here) being scaled down by a factor of 10, thus rendering the antenna's cavity 100 times as sensitive.

REFERENCES

- [1] J. C. Slater, *Microwave Electronics*. New York: Dover Publications, Inc., 1969, pp. 232-237.
- [2] D. G. Blair, E. N. Ivanov, M. E. Tobar, P. J. Turner, F. van Kann, and I. S. Heng, "High sensitivity gravitational wave antenna with parametric transducer readout", *Phys. Rev. Lett.*, vol. 74, pp. 1908-1911, March 1995.
- [3] K. Fujisawa, "General treatment of klystron resonant cavities", *IRE Trans. Microwave Theory Tech.*, vol. 6, pp. 344-358, Oct. 1958.
- [4] S. Timoshenko and S. Woinowsky-Krieger, *Theory of Plates and Shells*, New York: McGraw-Hill, 1959, p. 69.
- [5] O. D. Aguiar, et al. "The status of the Brazilian spherical detector", *Class. Quantum Grav.*, vol. 19, pp. 1949-1953, 2002.
- [6] "Na onda do gráviton", *Pesquisa FAPESP*, nº 61, pp. 42-45, jan./fev. 2001.